

The transmitter measures the humidity by the use of a laser trimmed, thermoset polymer capacitive sensing element. The microprocessor samples the humidity once per second. It calculates an averaging signal over a preset number of seconds and generates an output signal based on minimum and maximum humidity values. Standard range is 0...100% rH and 10 seconds average. The range and averaging samples may be customized.



Features

- ◆ Outdoor humidity measurement
- ◆ Programmable humidity range
- ◆ Minimum and maximum humidity memory
- ◆ 0...10V or 0...20mA measuring signals, selectable with jumpers
- ◆ Selectable averaging signal

Applications

- ◆ Humidity measurement in the field of heating, ventilation and air conditioning.
- ◆ Recording of minimum and maximum values for critical environments
- ◆ Supervision of critical humidity

Minimum and Maximum Values

Using the programming tool, the user has the option to read out and reset minimum and maximum values. The minimum and maximum values may as well be used as output signals. The minimum and maximum values are saved into the EEPROM and will be available after a power failure.

Dimensional Drawing

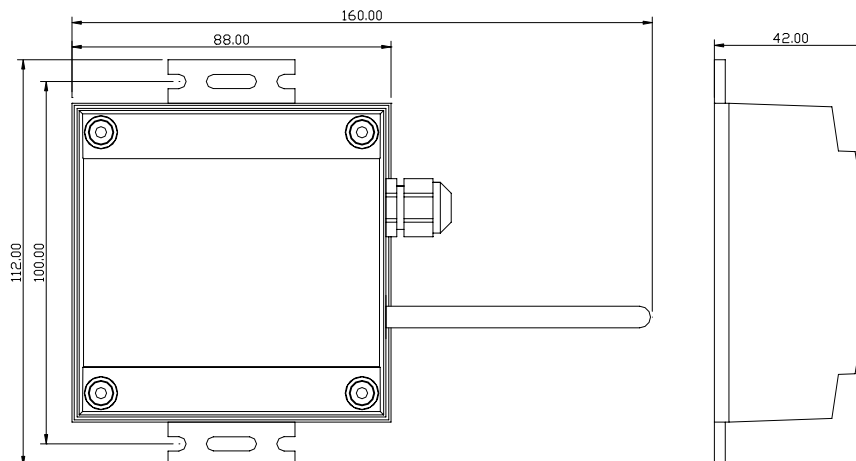

Specifications

Power Supply	Operating Voltage	24 V AC 50/60 Hz \pm 10%, 24VDC \pm 10%
	Power Consumption	Max 2 VA
	Electrical Connection	Terminal Connectors
Sensing Probe	Humidity Sensor:	Thermoset Polymer-Based Capacity
	Range	0...100 % rH
	Accuracy	\pm 3.0% at 25°C
	Hysteresis	\pm 3%
	Repeatability	\pm 0.5%
	Stability	\pm 0.5% / year if used within 0 to 50 °C
Connection	Connection Terminals	2.5 mm ²
Signal Outputs	Analog Outputs	
	Output Signal	DC 0-10V or 0...20mA
	Resolution	10 Bit, 9.7 mV, 0.019.5 mA
	Accuracy	\pm 2%
	Maximum Load	20 mA, 500 Ω
Environment	Operation	To IEC 721-3-3
	Climatic Conditions	class 3 K5
	Temperature	-40...70°C
	Humidity	<95% r.h.
	Transport & Storage	To IEC 721-3-2 and IEC 721-3-1
	Climatic Conditions	class 3 K3 and class 1 K3
	Temperature	-40...80°C
	Humidity	<95% r.h.
	Mechanical Conditions	class 2M2
Housing Materials	Cover & Mounting Plate	Fire proof ABS plastic
	Sensor immersion probe	Stainless Steel
Standards	 conform according to EMC Standard 89/336/EEC EMEI Standard 73/23/EEC	EN 61 000-6-1/ EN 61 000-6-3
	Product standards	
	Automatic electrical controls for household and similar use	EN 60 730 -1
	Special requirement on temperature dependent controls	EN 60 730 - 2 - 9
	Degree of Protection	IP65 to EN 60 529
	Safety Class	III (IEC 60536)
General	Dimensions [mm]	Cover: 42 x 112 x 88 (H x W x D) Probe: \varnothing 12 x 70 (Diameter x L)
	Weight (including package)	160g

Order Information

Item Name	Description/Option	
SOA-H1		Standard: 2...10V DC signal, 0...100%rH range
SOA-H1-W	0	Output Signal: 2...10V DC/ 4...20mA
	1	Output Signal: 0...10V DC/ 0...20mA
	2	Output Signal: Special – Specify